

WARNING:

DISCONNECT POWER BEFORE INSTALLING
DESUNA LA ELECTRICIDAD ANTES DE HACER REPARACIONES

INSTALLATION INSTRUCTIONS

1. Remove cover by removing (2) tamper proof-screws using security wrench supplied. Pull cover directly toward you. **IMPORTANT:** Save security wrench.
2. Dryers should be placed at least 2 feet (61cm) apart and at least 12" (30cm) from washbasin. Do not install dryer over washbasin. Automatic dryers should be at least 18" (46cm) above any projection which may interfere with the operation of the automatic sensor.

Hold the backplate to the wall at the suggested mounting height. Measure from bottom edge of **backplate** to the **floor** (Ref. Dimension "A", Fig. 1):

MEN	WOMEN	CHILDREN (depends on age)	DISABLED
44" (112cm)	42" (107cm)	32 to 42" (81-107cm)	36" (91cm)

3. Mark the locations of the four mounting holes and the conduit entrance location on the wall. (The conduit entrance is the proper hole diameter for 1/2 inch (13mm) conduit.)
4. Fasten the backplate to the wall where previously marked.

RECOMMENDATION:

Wood wall – No. 14 (M6) wood screws, 2 3/4" (70mm) long

Cement or brick – 1/4" (M6) stud expansion bolts, 3" (76mm) long

Hollow wall – 1/4" (M6) toggle bolts, length depends on wall thickness

5. Run service wire to the dryer location and connect to lead wires.
IMPORTANT: All units must be supplied with 3 wire service. Use No. 12 or 14 wire as required by local electrical code. The ground wire must be connected to the dryer ground screw. Unit must be installed by a qualified licensed electrician.

CONNECT TO A DEDICATED CIRCUIT NOT TO EXCEED 20 AMPS.

Dryers located in shower rooms or other wet locations should be equipped with ground fault interrupter(s).

6. **Carefully** replace the cover using (2) tamper-proof screws supplied. Apply a bead of caulk around edges of cover to wall.

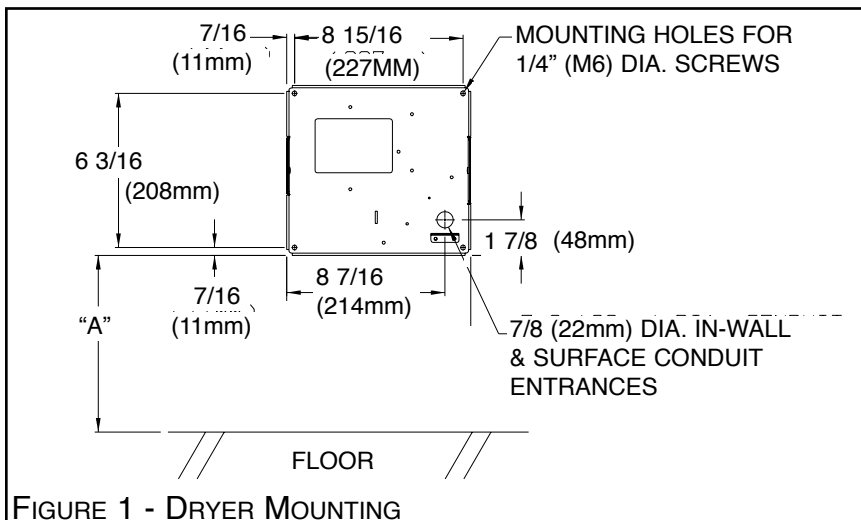

FIGURE 1 - DRYER MOUNTING

OWNER'S MANUAL GX SERIES HAND DRYERS

FOR INSTALLATION OR SERVICE ASSISTANCE PLEASE CALL (734) 421-2400 OR

IMPORTANT: HAVE MODEL & SERIAL NO. READY
MODEL # _____ SERIAL # _____

GLOBAL DRYER LIMITED WARRANTY

All parts of the **GX-M/C** models are warranted to the original consumer purchaser to be free from defects in material and workmanship for a period of five (5) years or three (3) years for **GX** models from the date of purchase from manufacturer. Sensor warranty three (3) years in the U.S.A. All models outside of the U.S.A., one (1) year including sensor. We will replace **FREE OF CHARGE**, during the warranty period, any warranted part which proves defective in material and/or workmanship under normal installation, use, and service, excluding normal wear. Replacement parts can be obtained by returning the part, **TRANSPORTATION CHARGES PREPAID**. You must notify factory prior to returning part or dryer. Any damage to this dryer as a result of misuse, abuse, neglect, accident, improper installation, unauthorized repairs, or any other use violative of instructions furnished by us, **WILL VOID THIS WARRANTY**. THIS WARRANTY IS IN LIEU OF ANY AND ALL WARRANTIES, EXPRESS OR IMPLIED, AND IS LIMITED TO THE REPLACEMENT OF DEFECTIVE PARTS ONLY. LABOR CHARGES AND/OR DAMAGE INCURRED IN INSTALLATION OR REPLACEMENT AS WELL AS ALL INCIDENTAL AND CONSEQUENTIAL DAMAGES CONNECTED THEREWITH ARE EXCLUDED.

GLOBAL DRYER®

MFD by AMERICAN DRYER, INC.

12932 FARMINGTON ROAD, LIVONIA, MI 48150, U.S.A.

Telephone (734) 421-2400

WARNING:

DISCONNECT POWER BEFORE INSTALLING
DESUNA LA ELECTRICIDAD ANTES DE HACER REPARACIONES

SERVICE AND MAINTENANCE OF YOUR DRYER

GENERAL OPERATION

This dryer is activated by an infrared sensor. The dryer operates as long as hands are below nozzle. There is a maximum 80 second running time with a safety over-ride feature, if hands are not removed. Each component used in your dryer has been designed to provide years of trouble-free service. However, if trouble should develop, it can normally be located by visual examination. Removal or replacement of most parts, is simple and can be done without special tools.

IF THE DRYER WON'T TURN ON:

Check electrical service, circuit breaker. Make sure proper voltage is being supplied to the dryer. Check for loose or disconnected terminal to sensor. INCREASE sensitivity (FIGURE 3) by using a flat-blade screwdriver and CAREFULLY turning the adjustment pot located on the sensor CLOCKWISE 1/3 Turn MAX. Turn . If necessary, replace sensor.

IF DRYER WILL NOT SHUT OFF:

Make certain black foam is attached to lens and lens is clean. If damaged, replace. DECREASE sensitivity (FIGURE 3) by CAREFULLY turning the adjustment pot located on the sensor. Use a small flat-blade screwdriver. 1/3 Turn MAX. COUNTER-CLOCKWISE. If necessary, replace sensor.

IF COLD AIR IS COMING FROM THE NOZZLE:

Turn off breaker for 30 seconds to reset thermostat. If required, remove the cover and vent, check the heating element. If the element is broken or burned out, replace it.

IF NO AIR IS COMING FROM THE NOZZLE AND HEATING ELEMENT GLOWS:

Remove the cover and check to see that the fan revolves freely. Check and replace motor, if required.

FOR ANY OTHER PROBLEM, CONTACT FACTORY FOR ASSISTANCE.

CLEANING - DO NOT spray cleaning solvents thru dryer vents. DO NOT use abrasive, chlorinated, or highly alkaline cleaners. DO NOT use oil based cleaners.

SEMI-ANNUALLY remove the cover and clean all lint and dust from the mechanism, inside of cover, and plastic window.

Clean cover with a mild soap or detergent and warm water, using a soft cloth or sponge.

PARTS LIST FOR YOUR DRYER (Figure 2)

ITEM	PART NO.	DESCRIPTION
1	GX202	COVER, WHITE ABS (MUST SPECIFY DRYER MODEL #)
2	GX202-M	COVER, WHITE STEEL (MUST SPECIFY DRYER MODEL#)
3	GX202-C	COVER, CHROME PLATED STEEL (SPECIFY DRYER MODEL #)
4	GX212	VENT ASS'Y W/ LENS AND FOAM GASKET
5	GX216	MOTOR, 110-120V INCLUDES BLOWER WHEEL (GX1)
6	GX217	MOTOR, 208-240V INCLUDES BLOWER WHEEL (GX3)
7	GX218	HEATING ELEMENT 110-120V (GX1)
8	GX220	HEATING ELEMENT 208-240V (GX3)
9	GX228	BLOWER WHEEL
10	GX239	SENSOR COMPLETE, 110-240 VOLT
11	GB232	TAMPER-PROOF SCREWS & SECURITY WRENCH

