

Model A Hand Dryer

Most Durable Standard Push-Button Hand Dryer



Distributed by
www.Ameraproducts.com
Phone: (800) 608-6568
Fax: (409) 840-5545
info@ameraproducts.com

WORLD DRYER

World Model A hand dryer is “the standard” hand dryer with the longest motor life and the best washroom solution for all high traffic applications.

Product Benefits

- 30 second drying time
- Longest life of all dryers
- Lowest sound level
- Durable and vandal resistant
- Classic style design

Design Features

Dryer

- Activated by electro-mechanical timer with 25 Amp switch
- 30 second drying cycle
- Incorporates a 2100 (optional 1500) watt Nichrome wire heating element Protected by an automatic-resetting, thermal cutoff
- Provides a 70° F temperature rise
- IPX1 ingress protection

Motor

- Thermally-protected, universal brush-type motor operating at 7,500 RPM
- Delivering 200 CFM air flow at a velocity of 7,300 LFM

Materials

- Cover material: Cast Iron with porcelain enamel finish. Optional 14GA polished or brushed finish #304S.S. or epoxy enamel finish C.R. Steel.
- The wall-mounted base is constructed of die-cast aluminum
- The nozzle is constructed of die-cast zinc alloy finished in bright chrome



Architecture & Engineering Specifications

World Dryer Model A hand dryers shall include a cover made of 1/4” thick cast iron with porcelain enamel finish. Optional 14GA polished or brushed finish #304S.S. or epoxy enamel finish C.R. Steel. Motor shall be universal type, 1/10 HP at 7500 RPM. Dryers shall deliver 200 cubic feet per minute of air volume (7300 LFM). Timer shall be electro-mechanical cam-style with 25 AMP rated switch to operate dryer for 30 second period. Hand dryers shall be listed under reexamination service of Underwriters Laboratories, Inc.

Model A Product Specifications

Electrical

	115 V	115 V	208 - 230 V	220 - 240 V	277 V
Amps	20	15	10	10	8.5
Watts	2300	1725	2300	2300	2300
Hz	60	60	60	50	60

Unit Size (HxWxD) inch/mm -

9.5” x 11.3” x 8.3” 241 mm x 287 mm x 211 mm

Shipping Size (HxWxD) inch/mm

12.5” x 14.4” x 10.1” 317 mm x 366 mm x 256 mm

Stock #	Cover Finish	Cover Material	Electrical	Unit Weight
A5-974	White	Cast Iron	115 V (20 Amp)	29 lbs/13.15 kgs
A52-974	White	Cast Iron	115 V (15 Amp)	29 lbs/13.15 kgs
A54-974	White	Cast Iron	208 - 230V	29 lbs/13.15 kgs
A548-974	White	Cast Iron	220 - 240 V	29 lbs/13.15 kgs
A57-974	White	Cast Iron	277 V	29 lbs/13.15 kgs
DA5-974	White	Stamped Steel	115 V (20 Amp)	18 lbs/8.16 kgs
DA52-974	White	Stamped Steel	115 V (15 Amp)	18 lbs/8.16 kgs
DA54-974	White	Stamped Steel	208 - 230V	18 lbs/8.16 kgs
DA548-974	White	Stamped Steel	220 - 240 V	18 lbs/8.16 kgs
DA57-974	White	Stamped Steel	277 V	18 lbs/8.16 kgs

Stock #	Cover Finish	Cover Material	Electrical	Unit Weight
DA5-972	Polished	Stainless Steel	115 V (20 Amp)	18 lbs/8.16 kgs
DA52-972	Polished	Stainless Steel	115 V (15 Amp)	18 lbs/8.16 kgs
DA54-972	Polished	Stainless Steel	208 - 230V	18 lbs/8.16 kgs
DA548-972	Polished	Stainless Steel	220 - 240 V	18 lbs/8.16 kgs
DA57-972	Polished	Stainless Steel	277 V	18 lbs/8.16 kgs
DA5-973	Brushed	Stainless Steel	115 V (20 Amp)	18 lbs/8.16 kgs
DA52-973	Brushed	Stainless Steel	115 V (15 Amp)	18 lbs/8.16 kgs
DA54-973	Brushed	Stainless Steel	208 - 230V	18 lbs/8.16 kgs
DA548-973	Brushed	Stainless Steel	220 - 240 V	18 lbs/8.16 kgs
DA57-973	Brushed	Stainless Steel	277 V	18 lbs/8.16 kgs

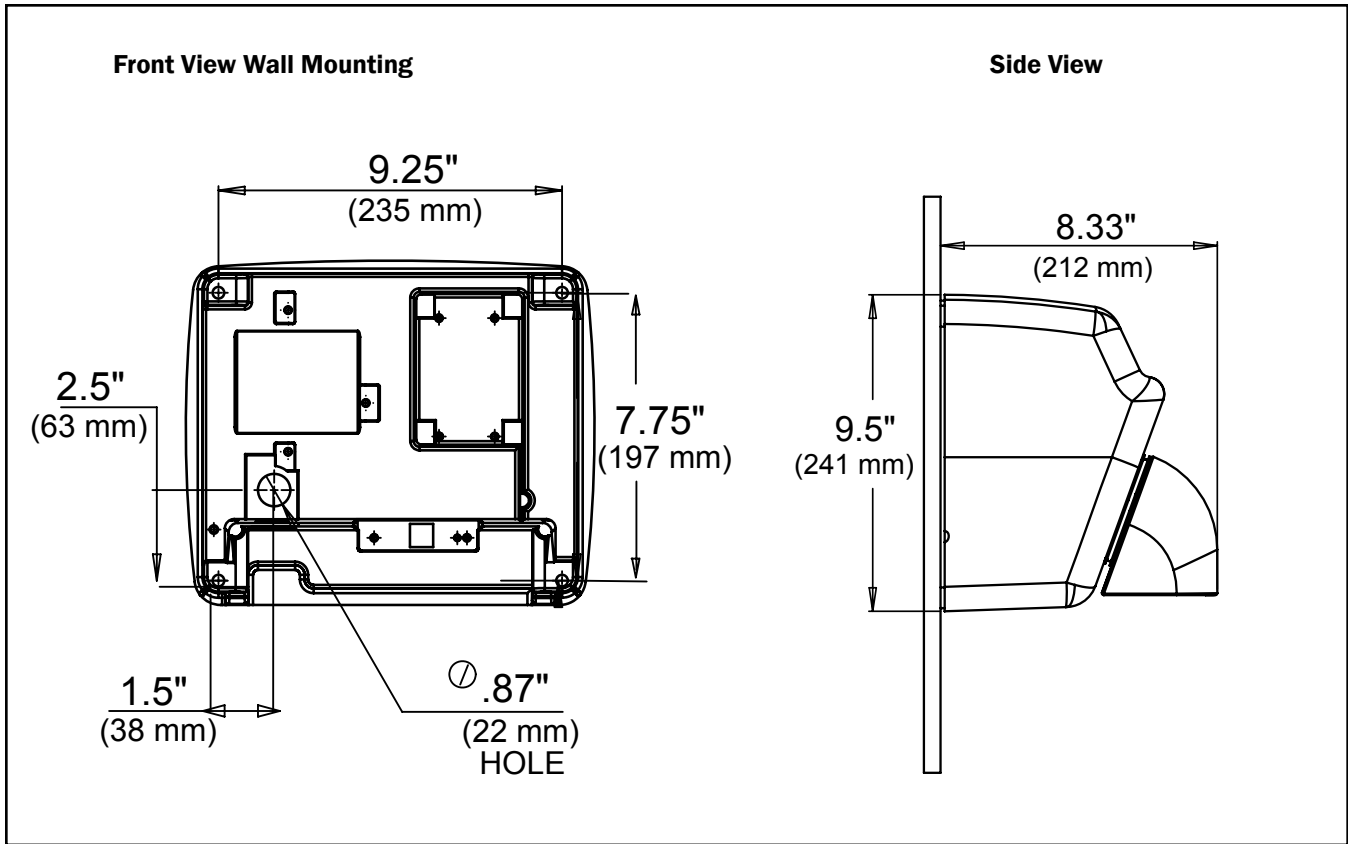

Placement Instruction

- Hand dryers should be spaced at least 2' apart, near but not over the wash basin
- In congested areas, dryers should be located to create a flow from wash basin to dryer to exit
- Dryer Quantity Recommendation:
 Average Traffic: 1 dryer per 2 wash basins
 Heavy Traffic: 1 dryer per wash basin
 Industrial 54" Circular wash fountains: 4 dryers per sink
- Recommended mounting heights from floor to dryer bottom edge

Men's washrooms	46" (117 cm)
Women's washrooms	44" (112 cm)
Children's washrooms, ages 4-7	32" (81 cm)
Children's washrooms, ages 7-10	36" (91 cm)
Children's washrooms, ages 10-13	40" (102 cm)
Children's washrooms, ages 13-17	44" (112 cm)
Handicap Mounting Height	37" (94 cm)

Measured from floor to the bottom of the unit.

Installation Guide

- Model A hand dryers require a dedicated 20 AMP circuit and must be properly grounded
- GFI circuit protection is recommended.
- One side of dryer should be mounted to a stud

Certification Approved



Warranty



10 year limited warranty

