

NOVA® 4 & Nova® 5



Quiet Hand Dryers

NOVA 4 & NOVA 5 are low-sound-level and durable hand dryers. The motors of NOVA 4 & NOVA 5 hand dryers are brushless, so no need for brush replacement. Both dryers are great washroom solutions for medium traffic facilities.

Product Benefits

- Quiet induction motor
- Easy maintenance brushless motor
- Automatic or push-button operation; Surface or recess mounted
- Durable and vandal resistant

Design Features

- Automatic unit - Activated by infrared sensor, automatic drying cycle.
- Push-button unit - timer shall be micro-chip based and microswitch activated. (NOVA 5 push button with adjustable dry timing)
- Thermally-protected, induction motor operating at 3,200 RPM
- Delivering up to 107 CFM air flow at a velocity of 4,400 LFM (50 MPH)

Architecture & Engineering Specifications

Nova® 4 & NOVA 5 hand dryers shall be manufactured by World Dryer Corporation to include a one-piece cover constructed of 0.2" thick cast iron (Nova 4) and finished in white acid-resistant porcelain enamel or 0.9" thick die cast aluminum finished in brushed chrome plating or epoxy coating (Nova 5). Dryers shall be fitted with 360° revolving die cast aluminum nozzles finished in bright chrome plating. Surface-mounted covers shall be fastened by two flathead, recessed tamper-resistant bolts to a heavy-gauge steel wall plate, which in turn shall be fastened to the wall or a wall box by four concealed mounting bolts. (For recessed dryers only: A steel wall box shall be furnished into which a complete base assembly shall be mounted). The dryer shall be equipped with 15 air intake slots (Nova 4) or 30 air intake slots (Nova 5). The fan shall be protected by an aluminum die cast grating fixed into the blower housing. The entire mechanism shall be internally grounded throughout. The motor shall be brushless, 1/10 H.P., 3200 RPM, thermally protected. The fan shall be a large single inlet centrifugal type contained in an aluminum die cast housing. It shall deliver 107 cubic feet per minute of air volume (4400 LFM) and shall be mounted directly on the motor shaft. The heating element of nichrome wire shall be mounted on the air intake. It shall be protected by an automatic resetting circuit breaker (25 AMP) which shall open whenever the air flow is cut off and shall close when the flow of air is resumed. The element shall produce an air temperature of 142 F at a 72 F ambient room temperature. The dryer shall be equipped with an infrared sensor which will allow the dryer to start automatically when hands are placed underneath the air nozzle, and to stop automatically when the hands are removed. For push button dryers (Nova 5 only), timer shall be micro-chip based and microswitch activated. It shall be adjustable to allow for the required time cycle setting. Nova Dryers shall be listed under reexamination service of Underwriters Laboratories, Inc.



NOVA® 4



NOVA® 5

Electrical specifications:

NOVA 4 & NOVA 5

	110-120 V	220-240 V
Amps	15	7.5
Watts	1800	1800
Hz	60 Hz	60 Hz

Cover options:

NOVA 4 - Cast iron with epoxy paint

NOVA 5 - Cast Aluminum with epoxy paint Drawn steel with porcelain enamel or brushed finish chrome plating



Product Line	110-120 V	208-240 V	Operation	Mounted	Cover Material, Cover Finish	Unit Wt.	Shipping Wt.	Unit Size (HxWxD) inch/mm	Shipping Size (HxWxD) inch/mm
NOVA 4	0412	0422	Automatic	Surface	Cast Iron, White	24.6 lbs 11.1 kgs	26.9 lbs 12.1 kgs	12.3" x 9.2" x 9.3" 312 x 234 x 236	14" x 11" x 13" 356 x 279 x 330
NOVA 4	0512*	-	Automatic	Surface	Cast Iron, White, Institutional	24.6 lbs 11.1 kgs	26.9 lbs 12.1 kgs	12.3" x 9.2" x 9.3" 312 x 234 x 236	14" x 11" x 13" 356 x 279 x 330
NOVA 4	0712	0722	Automatic	Recessed	Cast Iron, White	20.3 lbs 9.2 kgs	23.4 lbs 10.6 kgs	12" x 8" x 5.9" 305 x 203 x 150	14" x 11" x 13" 356 x 279 x 330
NOVA5	0112	0122	Push-Button	Surface	Aluminum, White	13.4 lbs 6.1 kgs	14.6 lbs 6.6 kgs	12" x 8.7" x 9.3" 305 x 221 x 236	14" x 11" x 13" 356 x 279 x 330
NOVA5	0212	0222	Automatic	Surface	Aluminum, White	12.9 lbs 5.8 kgs	14 lbs 6.3 kgs	12" x 8.7" x 9.3" 305 x 221 x 236	13" x 10" x 11" 330 x 254 x 279
NOVA5	011299	012299	Push-Button	Surface	Aluminum, Brushed Chrome	13.4 lbs 6.1 kgs	14.6 lbs 6.6 kgs	12" x 8.7" x 9.3" 305 x 221 x 236	13" x 10" x 11" 330 x 254 x 279
NOVA5	021299	022299	Automatic	Surface	Aluminum, Brushed Chrome	12.9 lbs 5.8 kgs	14 lbs 6.3 kgs	12" x 8.7" x 9.3" 305 x 221 x 236	13" x 10" x 11" 330 x 254 x 279
NOVA5	37-058500 Optional Recess Kit			Recessed	Steel, White Frame	6.8 lbs 3.1 kgs	8.1 lbs 3.7 kgs	15" x 13.2" x 5.9" 381 x 335 x 150	16" x 16" x 4" 406 x 406 x 100
NOVA5	37-058589 Optional Recess Kit			Recessed	Stainless Steel, Brushed Frame	6.8 lbs 3.1 kgs	8.1 lbs 3.7 kgs	15" x 13.2" x 5.9" 381 x 335 x 150	16" x 16" x 4" 406 x 406 x 100

NOVA 4 Surface Mounted Units

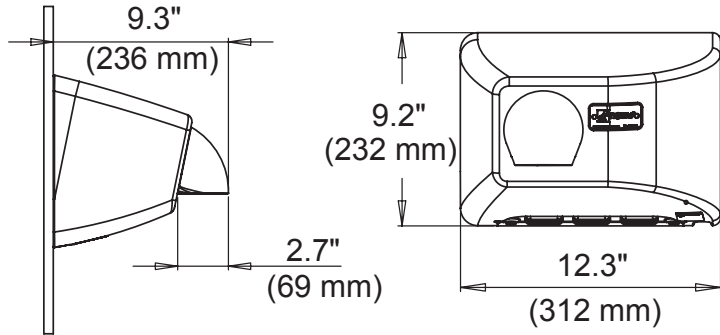

NOVA 5

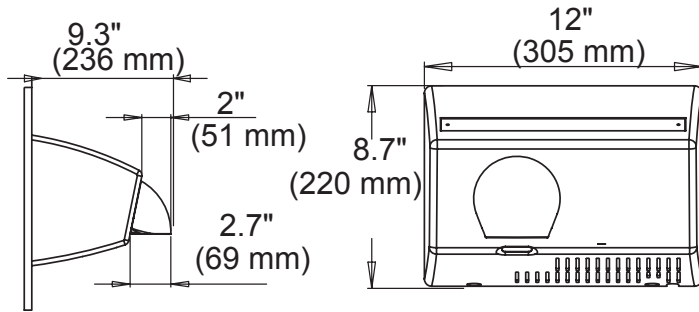

NOVA 4 Recess Mounted Units

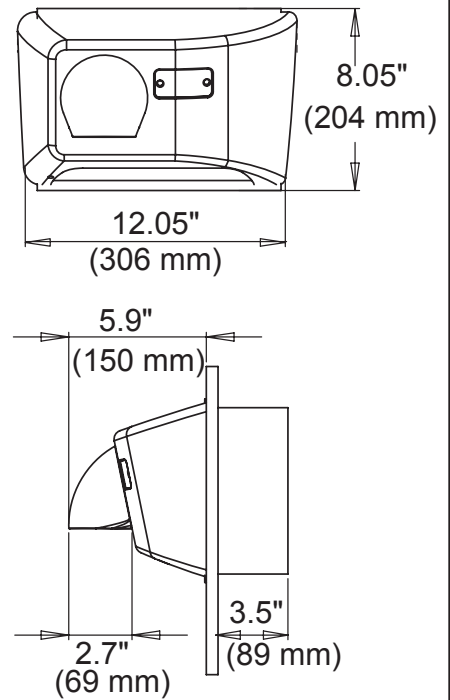

Placement Instruction

- Hand dryers should be spaced at least 2 feet apart, near but not over the wash basin
- In congested areas, dryers should be located to create a flow from wash basin to dryer to exit
- NOVA 4 & NOVA 5 should be mounted at least 18" above or away from reflective surfaces which may interfere with the automatic sensor operation.
- Dryer Quantity Recommendation:
Average Traffic: 1 dryer per 2 wash basins
Heavy Traffic: 1 dryer per wash basin
Industrial 54" Circular wash fountains: 4 dryers per sink
- Recommended mounting heights from floor to dryer bottom edge

Men's washrooms	46" (117 cm)
Women's washrooms	44" (112 cm)
Children's washrooms, ages 4-7	32" (81 cm)
Children's washrooms, ages 7-10	36" (91 cm)
Children's washrooms, ages 10-13	40" (102 cm)
Children's washrooms, ages 13-17	44" (112 cm)
Handicap Mounting Height	37" (94 cm)

Installation Guide

- NOVA 4 & NOVA 5 hand dryers require a dedicated circuit with a minimum rating of 15 amps and must be properly grounded
- GFI circuit protection is recommended
- One side of dryer should be mounted to a stud to minimize noise

Certifications



Distributed by
www.Ameraproducts.com
 Phone: (800) 608-6568
 Fax: (409) 840-5545
 info@ameraproducts.com

Warranty



5 year limited warranty
3 year sensor

92-MT014 Rev01