

# NOVA 1® AND NOVA 2® HAND DRYERS



## FACTS

- Saves up to 95% of paper towel costs*
- Reduces maintenance costs, vandalism and mess associated with paper towels*
- Saves trees from becoming paper towels*
- Reduces burden on clogged landfills*
- Uses less energy and produces fewer greenhouse gases than the production of paper towels*

## FEATURES

- Surface mounted, Automatic Activation, Nova 1® and Nova 2® Models are ADA compliant*
- Nova 1® 0830 and Nova2® 0930 Models are multi-voltage (100 VAC to 240 VAC)*
- Thermally protected motor, tamper resistant screws*
- Nova 1® Plug-in offers hassle free, quick installation*
- Nova 2® has dual blowers for maximum output*
- Suitable for light traffic areas*

## WARRANTY

- 2 year limited on Nova 1®*
- 2 year limited on Nova 1® Plug-in*
- 5 year limited on Nova 2®*

## NOVA 1® SPECIFICATIONS

Nova 1® hand dryers shall be manufactured by or for Nova Dryers® to include cover of die cast Aluminum with white epoxy enamel. Motor shall be thermally protected brush type with minimum 7500 RPM with a single shaft. Dryer shall deliver 134 cubic feet per minute of air volume (6400 LFM), and shall be activated by an infrared sensor, and controlled by a microprocessor that allows multi-voltage application (100 VAC to 240 VAC - 50 or 60 Hz). Dryer shall be surface mounted, and Nova 1® must not protrude more than 4 inches from the wall when hard-wired. Plug-in units shall be equipped with a 6 foot long cord and three-prong conductor plug, and shall include mounting bracket and hardware. Plug-in units available only in 120 VAC, 60 Hz for use with common wall outlets. Nova Dryers® shall be listed under reexamination service of Underwriters Laboratories, Inc. 

## NOVA 2® SPECIFICATIONS

Nova 2® hand dryers shall be manufactured by or for Nova Dryers® to include cover of drawn steel with porcelain enamel or drawn brushed finish 304 stainless steel. Motor shall be thermally protected brush type with minimum 7500 RPM with double shaft. Dryer shall contain dual blowers and deliver 220 cubic feet per minute of air volume (5300 LFM), and shall be activated by an infrared sensor, and controlled by a microprocessor that allows multi-voltage application (100 VAC to 240 VAC - 50 or 60 Hz). Dryer shall be surface mounted. Nova Dryers® shall be listed under reexamination service of Underwriters Laboratories, Inc. 

## SPECIFIER'S APPROVAL

Job _____	Date _____
Model Number _____	Quantity _____
Nova 2® Cover Option: White _____ Brushed Stainless Steel _____	
Variations _____	
Customer/Wholesaler _____	
Contractor _____	
Architect/ Engineer _____	



## ELECTRICAL SPECIFICATIONS

	Volts	Amps	Watts	Freq
NOVA 1 0830 - White Cover	120	8	1000	50 Hz or 60 Hz
	208	6	1000	
	240	7	1000	
NOVA 1 Plug-in 0833 - White Cover	120	8	1000	60 Hz
NOVA 2 0930 - White Cover 093079 - Brushed Stainless Steel Cover	120	15	2300	50 Hz or 60 Hz
	208	9	2300	
	240	10	2300	

## PLANNING GUIDE

### QUANTITY ESTIMATE

Average traffic:  
1 dryer per 2 washbasins  
Heavy traffic:  
1 dryer per washbasin  
54" Bradley sink:  
4 dryers per sink

### INSTALLATION

Hand dryers require a dedicated 15 AMP circuit (Model 0930 requires 20 amp circuit), and must be properly grounded. GFI Circuit protection is recommended. One side of dryer should be mounted to a stud.

### DRYER PLACEMENT

Hand dryers should be placed at least 2 feet apart, near but not over the washbasin. In congested areas dryers should be placed to create a traffic flow from wash basin to dryer to exit. Automatic dryers should be placed more than 18" above or away from projections, which may interfere with the operation of the automatic sensor.

### ADA COMPLIANCE

Nova 1 Model 0830 and Nova 2 Model 0930 dryers are ADA compliant

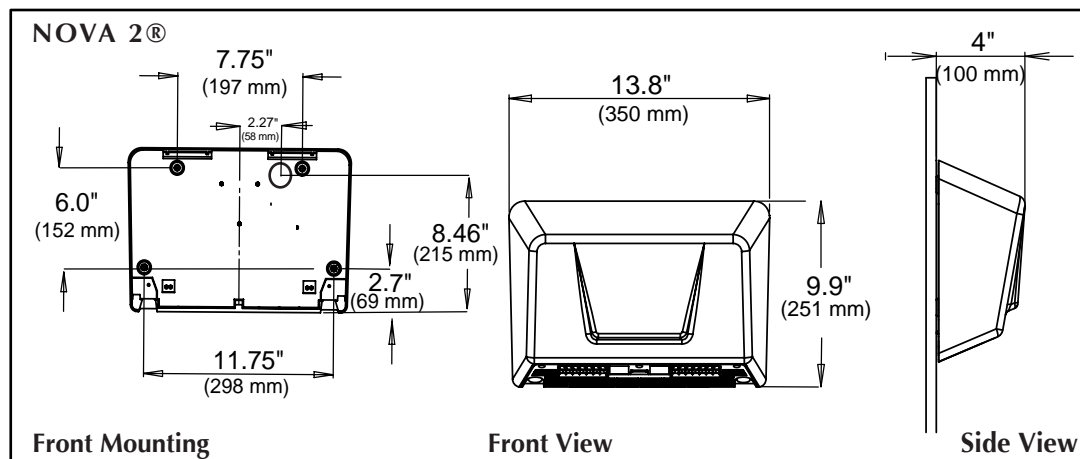
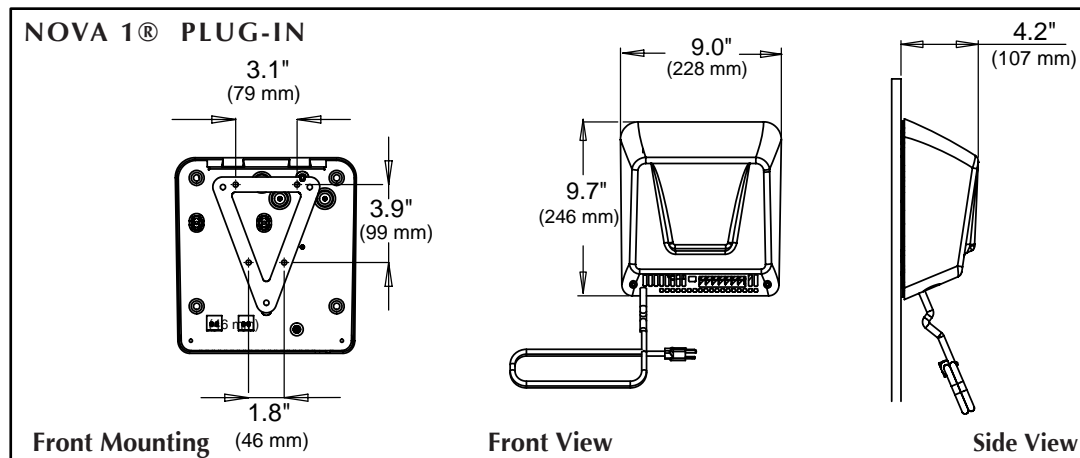
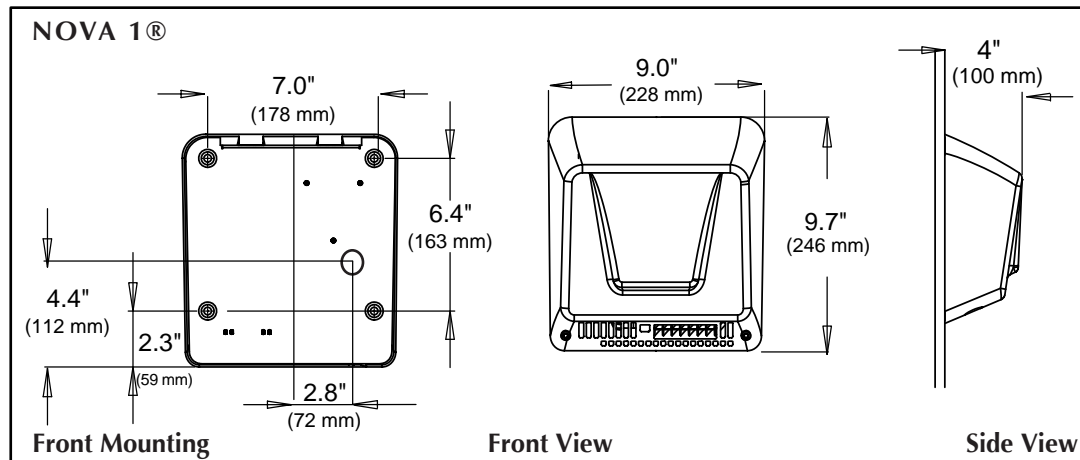

*Drawings not to scale*

## MOUNTING HEIGHTS

	Surface	Recessed
Men	46" (117cm)	42" (107cm)
Women	44" (112cm)	40" (102cm)
Children ages 3-7	32" (81cm)	28" (71cm)
Children ages 8-10	36" (91cm)	32" (81cm)
Children ages 11-13	40" (102cm)	36" (91cm)
Children ages 14-17	44" (116cm)	40" (102cm)
Disabled	37" (94cm)	34" (86cm)

Measured from floor to the bottom of the unit

## MEASUREMENTS

MODEL	MEASUREMENTS	SHIPPING MEASUREMENTS	
		WEIGHT	DIMENSIONS
Nova 1	9.2 W x 9.7" H x 4" D	10 lbs	13" L x 12" W x 8" H
Nova 1 Plug-in	9.2 W x 9.7" H x 4.2" D	10 lbs	13" L x 12" W x 8" H
Nova 2	14" W x 10" H x 4" D	12 lbs	16" L x 13" W x 8" H

