

American® DR and A Series SPECIFICATIONS

Maintenance free
 Quiet, dependable operation
 360° revolving nozzle
 Vandal resistant
 Durable finish looks new for years
 10 year limited warranty



OVERVIEW:

THE DR AND A SERIES HAND DRYERS' TIME-TESTED DESIGN FEATURES QUIET, DEPENDABLE OPERATION IN A HEAVY DUTY, VANDAL-RESISTANT PACKAGE.

construction features:

DR SERIES COVER & FINISH – One-piece, heavy duty, 16 gauge steel with white enamel finish or optional 18 gauge type 304 stainless steel with brushed finish (SS).

A SERIES COVER & FINISH – One-piece, heavy duty, 1/4" thick cast iron cover with white porcelain enamel finish is the ultimate in vandal resistance.

TAMPER RESISTANT – Tamper resistant screws secure cover to base. Air intake vents are shielded for additional safety.

MOTOR – Permanently lubricated, maintenance free, brushless induction motor with automatic resetting thermal protector. 1/10 HP, 3200 RPM.

NOZZLE & PUSH BUTTON – Chrome plated zinc die castings. 360° revolving nozzle is standard. A fixed nozzle (F) is optional on all models.

DR SERIES TIMER – Push button models use a heavy duty timer for extended life. Turns on with a light touch. Turns off automatically.

AUTOMATIC SENSOR – RoHS compliant lead-free design. Microprocessor controlled infrared sensor turns dryer on when hands are under the outlet for up to 80 seconds.

HEATING ELEMENT – Constructed of NiChrome resistance wire with automatic resetting thermostat. Side mounted heating element operates in the black range for maximum life.

specifications DR and A	
AIR FLOW	160 CFM (Cubic Feet per Min.)
AIR VELOCITY	5500 LFM (Linear Feet per Min.)
AIR TEMP	130 - 145°F at 72°F Ambient
SOUND LEVEL	71 dB (Quietest in its class)
DIMENSIONS SURFACE	DR 11" W x 9-1/4" H x 8-7/8" D
	A 11-3/8" W x 9-7/8" H x 8-7/8" D
DIMENSIONS RECESSED	DR 15-5/8" W x 12-3/8" H x 5-5/8" D
	A 12-1/2" W x 10-1/16" H x 6" D
WARRANTY: 10-year limited warranty. Includes same day factory repair or part replacement. Sensor 5 years. See owner's manual for details.	

DR model reference chart

PUSH BUTTON		AUTOMATIC		ELECTRICAL RATINGS			
Surface Model	Drying Cycle	Surface Model	Drying Cycle	Volts	Amps	Watts	Hertz
DR10N	40 sec	DR10TN	Auto	110-120	15	1725	60
DR20N	30 sec	DR20TN	Auto	110-120	20	2300	60
DR35N	30 sec	DR35TN	Auto	208-240	10	2300	50/60

AVAILABLE OPTIONS:
Stainless steel cover add (SS) after model no. **Fixed nozzle** add (F) after model no.
Hair drying with 80 second cycle add (H) after model no. Automatic models only.
Recess Mounted add (R) after model no. or order kit separately.

A model reference chart

AUTOMATIC			ELECTRICAL RATINGS			
Surface Model	Recessed Model	Drying Cycle	Volts	Amps	Watts	Hertz
A70T	A70TR	Auto	110-120	20	2300	60
A80T	A80TR	Auto	208-240	10	2300	50/60

AVAILABLE OPTIONS: Fixed nozzle add (F) after model no.

DR Series Mounting Diagrams

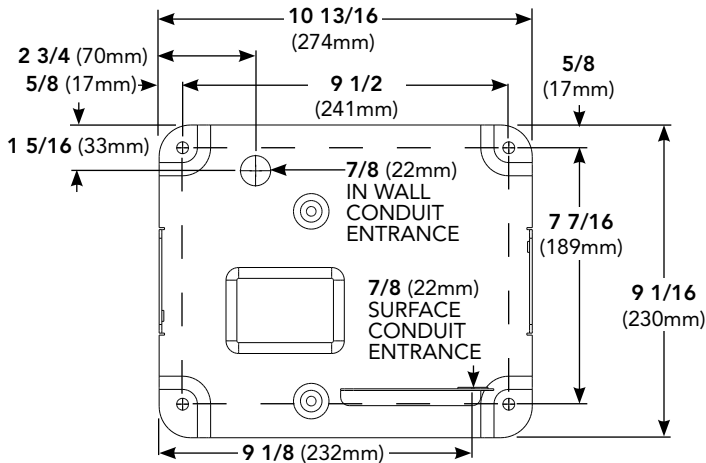
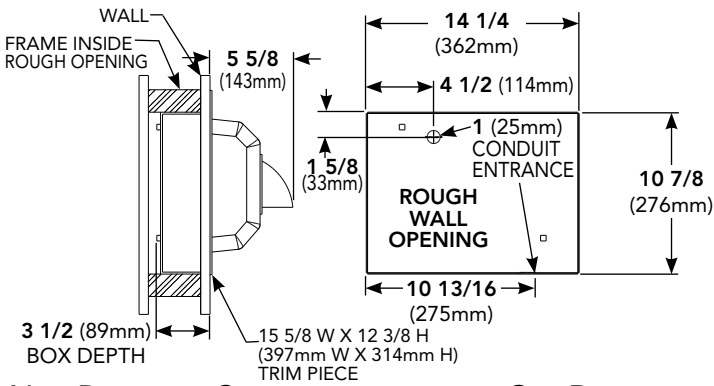

Figure 1 - DR Series Surface Mount



NEW REVISION - CONSULT FACTORY FOR OLD DIMENSIONS

Figure 2 - DR-R Series Recessed Mount

A Series Mounting Diagrams

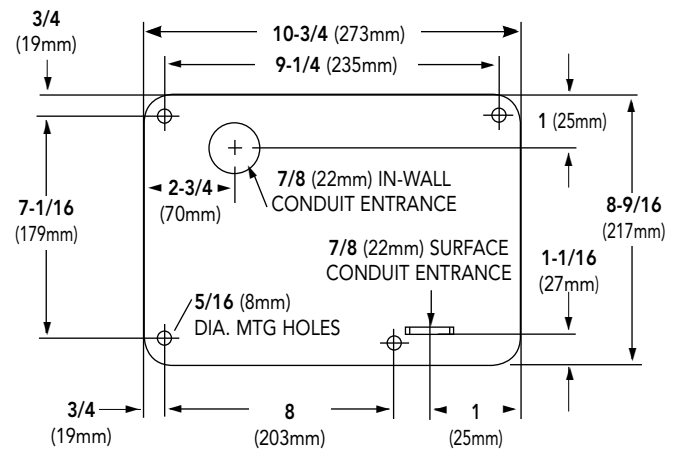

Figure 3 - A-T Series Surface Mount

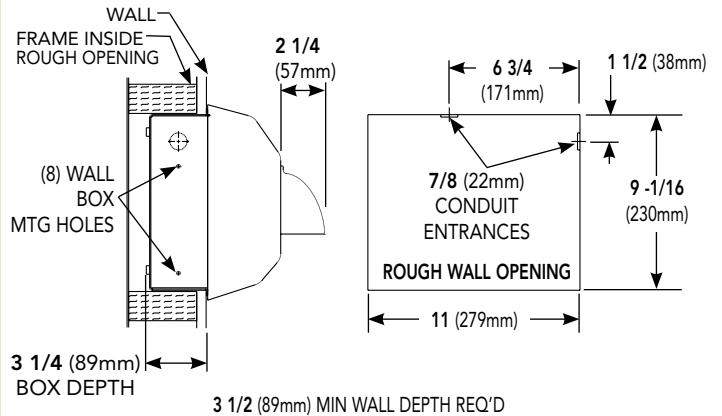

Figure 4 - A-TR Series Recessed Mount

Represented by:



DRYER PLACEMENT:

Dryers should be placed at least 2 feet apart and at least 12" from washbasin. Do not install dryer over washbasin. Automatic dryers should be at least 18" above any projection which may interfere with the operation of the automatic sensor.

DRYER INSTALLATION:

Hand dryers require a dedicated circuit (max. 20 amp) and must be properly grounded. One side of dryer should be mounted to stud. All surface mount dryers are provided with conduit entrances for both between wall and surface wiring.

QUANTITY ESTIMATE, HAND DRYER:

Average traffic washroom.....1 dryer per 2 washbasins
Heavy traffic washroom.....1 dryer per washbasin
54" wash fountain.....4 dryers per sink

SHIPPING WEIGHT:

DR Series 16 lbs, A Series 28 lbs

Printed on Recycled Paper

